

Description

The beverage mixer type **DIMIX-C™** combines the functions of the:

- Water deaerating system type **DIOX1(2)-T™**
- In-line blending system type **DICON-C2™** for 2 components
- Carbonating system type **DICAR-C™**

to a compact unit which is particularly suitable for the production of soft drinks.

The water deaerating system type **DIOX1(2)-T™** enables an optimum deaeration of the product water (see our data sheet for the **DIOX1(2)-T™**).

Finished syrup and water are continuously mixed in the in-line blending system type **DICON™** (see our data sheet for the **DICON-C2™**).

The product flows are measured by high-precision flow meters and compared in the digital controller in consideration of the desired mixing ratios. Deviations are precisely compensated. A great variety of flow ranges and ratio ranges can be covered by the large selection of flow meters.

Finished beverage is supplied via a special CO₂ saturator to the buffer tank of the **DICAR™** (see our technical data sheet for the **DICAR-C™**).

Specific parameters are stored in the recipes in order to obtain the required quality parameters for different products and operating states immediately from the start of production.

Features

- Efficient water deaeration (≤ 0.7 mgO₂/l) (0.05 mg O₂/l on request)
- High-precision flow measurement for water and finished syrup
- Control deviations are fully compensated by the digital ratio control which ensures a constantly high product quality
- Carbonation of 10 gCO₂/l of product max.
- Small CO₂ losses only
- Intelligent control for the minimization of product losses and product changing times
- Option : In-line measurement of CO₂, Brix, Conductivity and O₂ (other parameters on request)
- Compact factory-tested unit

Scheme (Example DIMIX-C™)

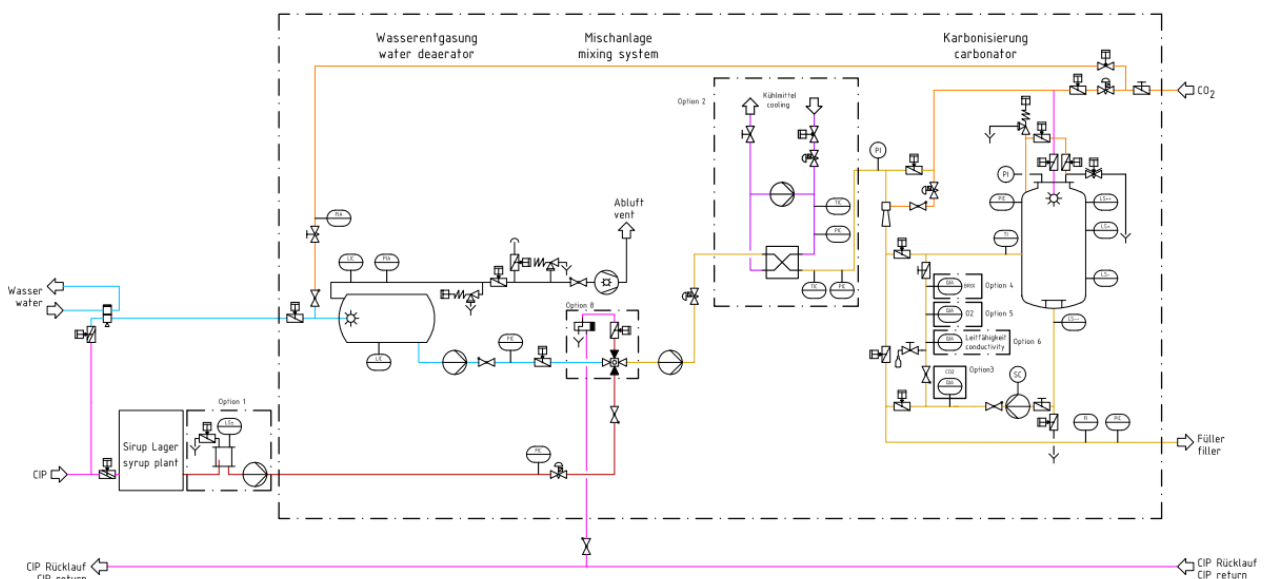

The DIMIX-C™ is available with the following options:

1. Deaerating lantern for finished syrup
2. Cooler
3. CO₂-measurement
4. Brix measurement
5. O₂ measurement
6. Conductivity measurement
7. Separate CIP for syrup line

Technical data

Materials	1.4301/EPDM, other materials on request																																																					
Dimensions	Qmax.	Length	Width	Height	Nominal width	Installed electrical power	Weight approx.																																															
	l/h	mm	mm	mm	DN	kW	kg																																															
	20,000	3,500	1,800	3,850	65	20	1,800																																															
	35,000	3,500	1,800	3,850	80	36	2,200																																															
	55,000	3,900	2,250	4,450	100	45	2,800																																															
	other flow rates possible on request																																																					
Product	Soft drinks of a maximum particle size of 0.5 mm and a maximum viscosity of 10 mPas																																																					
Water deaeration	Residual oxygen content < 0.7 mg/l (0.05 mg/l on request)																																																					
Carbonation	10 g/l or 5 l/l maximum (at a CO ₂ content of 0 g/l and a maximum oxygen content of 0.7 mg/l in the beverage at the inlet of the system)																																																					
	<div style="text-align: center;"> CO₂ saturation of soft drinks </div> <table border="1" style="display: none;"> <caption>CO₂ saturation of soft drinks (Estimated data from graph)</caption> <thead> <tr> <th>Temperature (°C)</th> <th>2.0 bar</th> <th>2.5 bar</th> <th>3.0 bar</th> <th>3.5 bar</th> <th>4.0 bar</th> </tr> </thead> <tbody> <tr> <td>10</td> <td>3.7</td> <td>4.3</td> <td>4.9</td> <td>5.5</td> <td>6.2</td> </tr> <tr> <td>12</td> <td>3.5</td> <td>4.1</td> <td>4.7</td> <td>5.3</td> <td>5.9</td> </tr> <tr> <td>14</td> <td>3.3</td> <td>3.9</td> <td>4.5</td> <td>5.0</td> <td>5.6</td> </tr> <tr> <td>16</td> <td>3.1</td> <td>3.7</td> <td>4.3</td> <td>4.8</td> <td>5.4</td> </tr> <tr> <td>18</td> <td>3.0</td> <td>3.5</td> <td>4.1</td> <td>4.6</td> <td>5.2</td> </tr> <tr> <td>20</td> <td>2.9</td> <td>3.4</td> <td>3.9</td> <td>4.4</td> <td>5.0</td> </tr> <tr> <td>22</td> <td>2.8</td> <td>3.3</td> <td>3.7</td> <td>4.2</td> <td>4.8</td> </tr> </tbody> </table>							Temperature (°C)	2.0 bar	2.5 bar	3.0 bar	3.5 bar	4.0 bar	10	3.7	4.3	4.9	5.5	6.2	12	3.5	4.1	4.7	5.3	5.9	14	3.3	3.9	4.5	5.0	5.6	16	3.1	3.7	4.3	4.8	5.4	18	3.0	3.5	4.1	4.6	5.2	20	2.9	3.4	3.9	4.4	5.0	22	2.8	3.3	3.7	4.2
Temperature (°C)	2.0 bar	2.5 bar	3.0 bar	3.5 bar	4.0 bar																																																	
10	3.7	4.3	4.9	5.5	6.2																																																	
12	3.5	4.1	4.7	5.3	5.9																																																	
14	3.3	3.9	4.5	5.0	5.6																																																	
16	3.1	3.7	4.3	4.8	5.4																																																	
18	3.0	3.5	4.1	4.6	5.2																																																	
20	2.9	3.4	3.9	4.4	5.0																																																	
22	2.8	3.3	3.7	4.2	4.8																																																	
CO ₂ quality	≥ 99.99 % purity																																																					
Control air	6 – 8 bar																																																					

Figure (Example DIMIX-C™ Qmax. 7,000 l/h)

