

Description

Oxygen in beer or soft drinks affects their preservability and taste. Therefore, it is important to use deaerated water for the production of soft drinks and for the redilution of beer. The GEA Diessel 2-stage water deaerating system, type **DIOX-2™**, achieves excellent residual oxygen values and is thus especially suitable for this and some other applications.

In the first stage the largest part of the oxygen is extracted by means of the vacuum deaeration. In the second stage the oxygen content is reduced further to the desired value by the addition of CO₂ or N₂. The mixture of stripping gas and oxygen is continuously sucked off by means of the vacuum pump. A transfer pump conveys the deaerated water to the buffer tank or the consumer.

The system is cleaned via the product line.

The **DIOX-2™** is available in the following versions:

- **DIOX-2™** liquid-ring vacuum pump residual O₂ <0.05mg/l Qmax. <900 hl/h
- **DIOX-2T™** dry-running vacuum pump residual O₂ <0.05mg/l Qmax. <600 hl/h
(also available with 1 deaerating tank residual O₂ <0.05mg/l Qmax. <200 hl/h)

Features

- Low residual oxygen content ≤0.05 mgO₂/l)
- Low stripping gas consumption (0 – 0.5 g/l)
- Low assembly costs, as pre-assembled and tested ready for operation
- Flow rates from 50 – 900 hl/h available

Flow diagram (Example DIOX-2T™: Qmax. >200 hl/h)

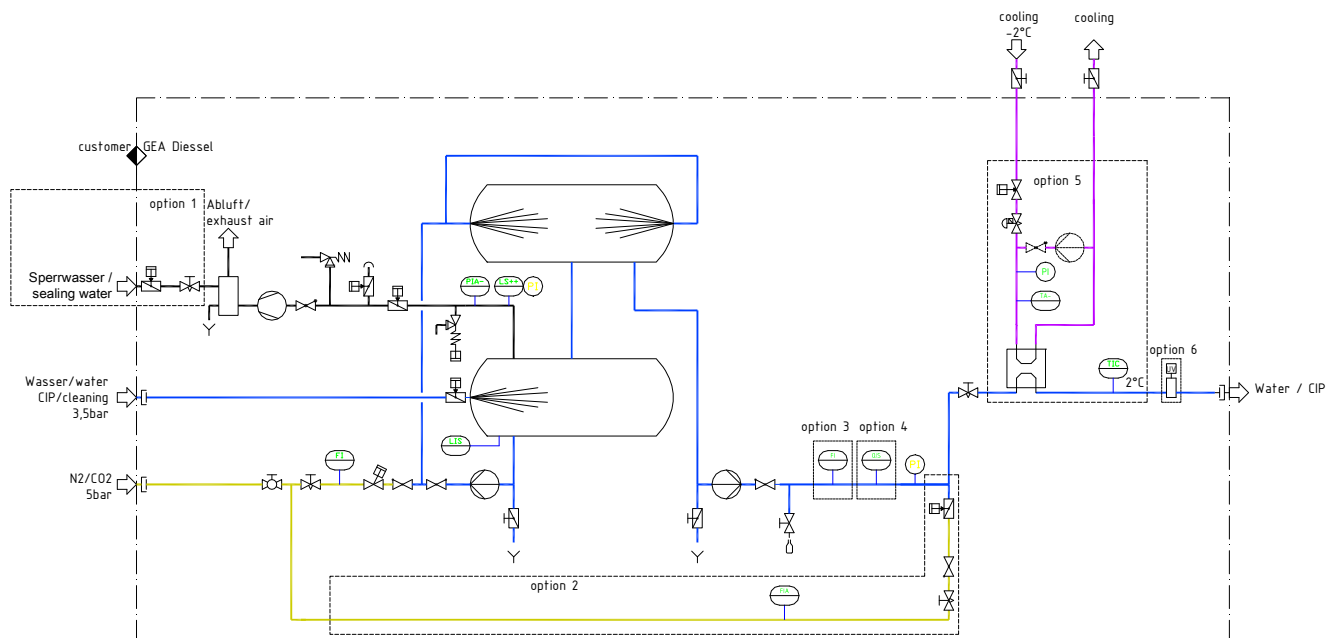

The DIOX-2T™ and DIOX-2™ systems are available with the following options:

- | | |
|----------------------------|-------------------------------|
| 1. Liquid-ring vacuum pump | 4. O ₂ measurement |
| 2. Precarbonation | 5. Cooler |
| 3. Flow meter | 6. UV sterilization |

Technical data

Materials	1.4301/EPDM other materials on demand																																																																						
Dimensions	<table border="1"> <thead> <tr> <th>Qmax hl/h</th> <th>Length mm</th> <th>Width mm</th> <th>Height mm</th> <th>DN</th> <th>Installed electrical power kW</th> <th>Approx. max. weight kg</th> </tr> </thead> <tbody> <tr><td>50</td><td>2,900</td><td>1,300</td><td>2,900</td><td>40</td><td>9</td><td>2,000</td></tr> <tr><td>100</td><td>2,900</td><td>1,300</td><td>2,900</td><td>50</td><td>12</td><td>2,000</td></tr> <tr><td>200</td><td>2,900</td><td>1,300</td><td>3,250</td><td>65</td><td>20</td><td>2,000</td></tr> <tr><td>300</td><td>2,900</td><td>1,700</td><td>3,250</td><td>80</td><td>25</td><td>2,500</td></tr> <tr><td>400</td><td>2,900</td><td>1,700</td><td>3,250</td><td>80</td><td>33</td><td>2,500</td></tr> <tr><td>500</td><td>3,600</td><td>1,800</td><td>3,600</td><td>100</td><td>36</td><td>3,000</td></tr> <tr><td>600</td><td>3,600</td><td>1,800</td><td>3,600</td><td>100</td><td>40</td><td>3,000</td></tr> <tr><td>750</td><td>3,600</td><td>1,800</td><td>4,200</td><td>100</td><td>55</td><td>3,500</td></tr> <tr><td>900</td><td>3,600</td><td>1,800</td><td>4,200</td><td>100</td><td>65</td><td>4,200</td></tr> </tbody> </table>	Qmax hl/h	Length mm	Width mm	Height mm	DN	Installed electrical power kW	Approx. max. weight kg	50	2,900	1,300	2,900	40	9	2,000	100	2,900	1,300	2,900	50	12	2,000	200	2,900	1,300	3,250	65	20	2,000	300	2,900	1,700	3,250	80	25	2,500	400	2,900	1,700	3,250	80	33	2,500	500	3,600	1,800	3,600	100	36	3,000	600	3,600	1,800	3,600	100	40	3,000	750	3,600	1,800	4,200	100	55	3,500	900	3,600	1,800	4,200	100	65	4,200
Qmax hl/h	Length mm	Width mm	Height mm	DN	Installed electrical power kW	Approx. max. weight kg																																																																	
50	2,900	1,300	2,900	40	9	2,000																																																																	
100	2,900	1,300	2,900	50	12	2,000																																																																	
200	2,900	1,300	3,250	65	20	2,000																																																																	
300	2,900	1,700	3,250	80	25	2,500																																																																	
400	2,900	1,700	3,250	80	33	2,500																																																																	
500	3,600	1,800	3,600	100	36	3,000																																																																	
600	3,600	1,800	3,600	100	40	3,000																																																																	
750	3,600	1,800	4,200	100	55	3,500																																																																	
900	3,600	1,800	4,200	100	65	4,200																																																																	
Admission pressure for water	3.5 bar																																																																						
Admission pressure for CO ₂	5 bar																																																																						
Control air pressure	6 – 8 bar																																																																						
CO ₂ consumption	0 – 0.5 g/l																																																																						
Required CO ₂ quality	≥99.99 % purity																																																																						
Residual oxygen content																																																																							

Figure (Example DIOX-2T™: Qmax. 300 hl/h)

