

Description

GEA Diessel in-line blending systems type **DICON-C** are designed for the continuous high-precision mixing of soft drinks. The number of the components to be mixed is not limited. Flow rates from 2 l/h are possible in the concentrate lines.

Liquid flows are measured by accurate flow meters (such as mass flow meters type MDM or electromagnetic flow meters type IZM) and transmitted to the automatic system controller. The digital controller compares the measured values in consideration of the preselected mixing ratios and actuates the controlling devices in such a way that the preset values are exactly kept. Short-termed control deviations are completely compensated.

Deaerating and test vessels prevent any air occlusions and thus even any potential measuring errors. Apart from that they permit the cyclical monitoring of the flow meters for the concentrates. Modulating valves and/or positive pumps with frequency converter are used as controlling devices. The in-line blending system is followed by the carbonator type DICAR, wherein the desired CO₂ content is set. Essential product criteria like Brix value and conductivity are determined and monitored on-line in the DICAR carbonator. If desired, an automatic correction (e.g. of Brix deviations) can be carried out within the DICON-C system, too.

Special features and advantages:

- Direct mixing of the products in the pipeline, no mixing tanks required.
- Small product quantities only are included in the system, quick availability of the product.
- High accuracy by the use of precise flow meters.
- Cyclical monitoring of the flow meters during the running process.
- The digital controller is not subject to any fault caused by the signal conversion and compensates any short-termed deviations completely.
- Easy handling.
- Compact factory-tested device, ready for connection.
- Can be combined with the carbonator type DICAR.

Scheme: Fully automatic in-line blending system for 5 components (example)

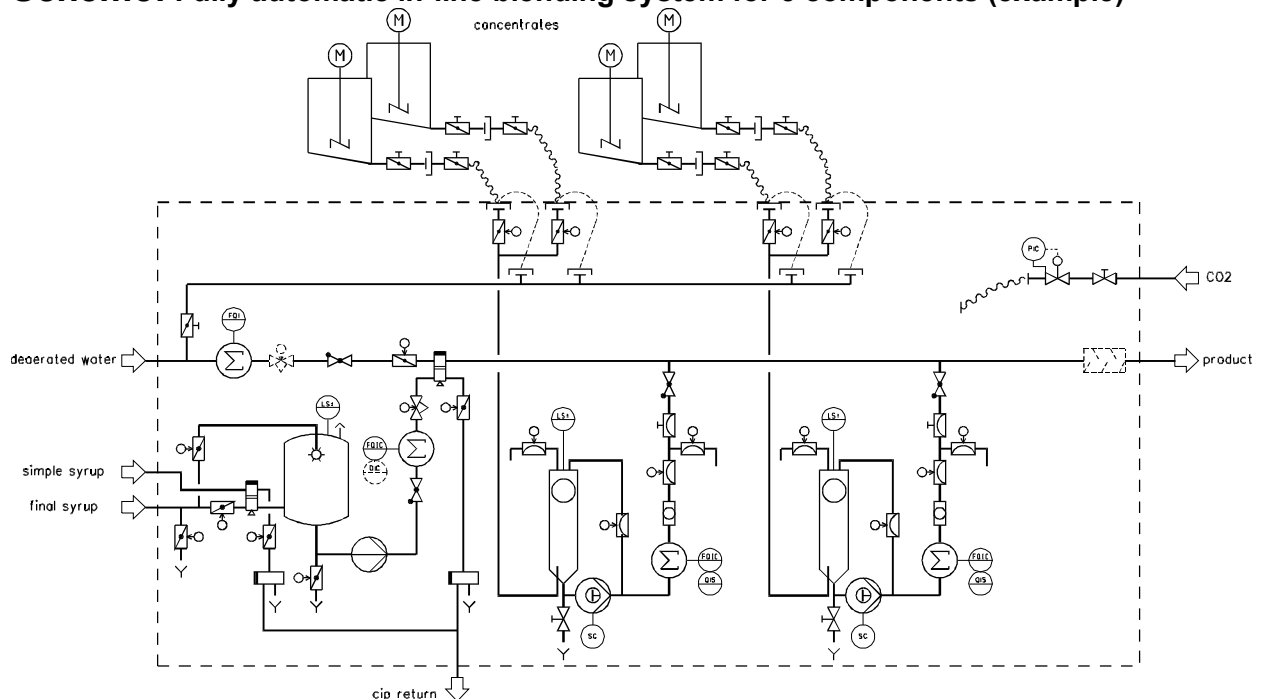

GEA Diessel GmbH
 Steven 1
 31135 Hildesheim
 Germany
 ☎ +49 5121 / 742-0

**In-line Blending System
 DICON-C
 for the continuous mixing of
 soft drinks**

D 46.42 E

Issued: 11.2004

Page 1 of 2 pages

Technical data

Blending flow rate:	15,000 l/h, 25,000 l/h, 35,000 l/h and 55,000 l/h (an adaptation to the filler capacity is possible), other flow rates on demand.
Pressures:	<i>Water inlet:</i> 2.5 bar \pm 0.25 bar <i>Sugar syrup:</i> 0.5 bar <i>Concentrates:</i> independent supply by gravity (min. outlet height of the container 1 m) <i>Counterpressure at the outlet:</i> up to 1.5 bar
Nominal system pressure:	6 bar
Dosing accuracy of the components:	$\leq \pm 0.25$ %
Brix accuracy:	$\leq \pm 0.03^\circ$ Brix at a constant Brix value in sugar syrup or finished syrup or with a built-in accessory unit for the „Brix measurement in sugar syrup/finished syrup“
Dimensions:	To a certain extent the dimensions are dependent of the flow rate and the number of components. Example: Dimensions of a 5-components system with a blending flow rate of 35,000 l/h: Width 2,400 mm, height 2,000 mm, depth 1,200 mm
Accessories:	<ul style="list-style-type: none">- Brix measurement in sugar syrup/finished syrup with an automatic correction of the ratio referred to water.- Control of the total flow rate by an additional modulating valve in the water component.- Static mixer in the mixing line.- Measuring system in the concentrate lines for the recognition of any wrongly connected products.- Fixed connection for blowing out the concentrate lines (recommendable in case of frequent concentrate changes).- Automated CIP connection with leakage protection (see the scheme on the 1st page of this data sheet).