

Description

GEA Diessel in-line blending systems type **DICON-S** are designed for the continuous high-precision mixing of syrup for soft drinks. The number of the components to be mixed is not limited. Flow rates from 2 l/h are possible in the concentrate lines.

Liquid flows are measured by accurate flow meters (such as mass flow meters type MDM or electromagnetic flow meters type IZM) and transmitted to the automatic system controller. The digital controller compares the measured values in consideration of the preselected mixing ratios and actuates the controlling devices in such a way that the preset values are exactly kept. Short-termed control deviations are completely compensated.

Deaerating and test vessels prevent any air occlusions and thus even any potential measuring errors. Apart from that, they permit the flow meters for concentrates to be cyclically monitored. Modulating valves and/or positive pumps with frequency converter are used as controlling devices. A static mixer in the mixing line ensures a homogeneous product.

The in-line blending system is followed by a small buffer tank. Essential product criteria like Brix value and (if necessary) conductivity are determined and monitored in-line. If desired, an automatic correction (e.g. of Brix deviations) can be carried out within the DICON-S system, too.

Special features and advantages:

- Direct mixing of the products in the pipeline, i.e. the system includes small product quantities only
- Quick availability of the product
- No large mixing tanks necessary, small space required only
- High accuracy by the use of precise flow meters
- Cyclical check of the flow meters during the running process
- The digital controller is not subject to any fault caused by the signal conversion and compensates any short-termed deviations completely.
- Easy handling
- Compact factory-tested device, ready for connection

Scheme: Fully automatic in-line blending system for 4 components (example)

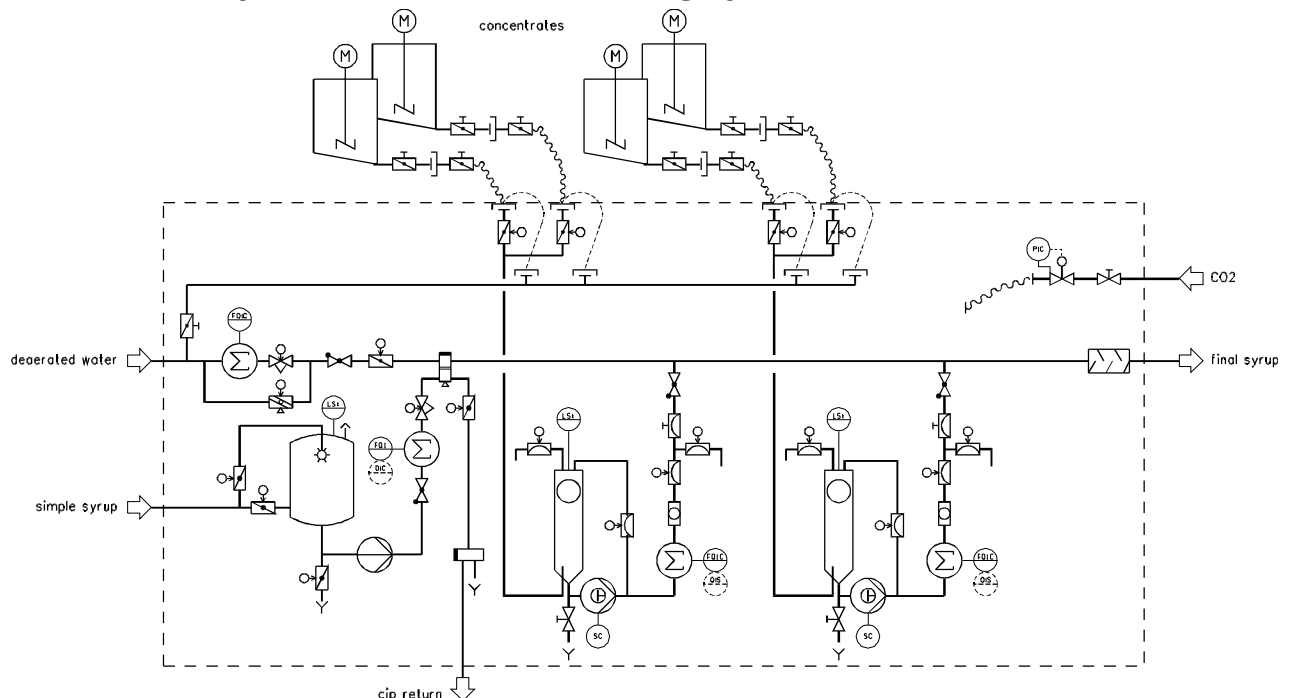

GEA Diessel GmbH
 Steven 1
 31135 Hildesheim
 Germany
 ☎ +49 5121 / 742-0

**In-line blending system type
 DICON-S
 for the continuous mixing of syrup for
 soft drinks**

D 46.44 E

Issued: 11.2004

Page 1 of 2 pages

Technical data

Blending flow rate:	12,000 l/h, 20,000 l/h, 30,000 l/h, and 40,000 l/h, other flow rates on demand
Pressures:	<i>Water inlet:</i> 2.5 bar +/-0.25 bar <i>Sugar syrup:</i> 0.5 bar <i>Concentrates:</i> independent supply by gravity (min. outlet height of the container: 1 m) <i>Counterpressure at the outlet:</i> up to 1.5 bar
Nominal system pressure:	6 bar
Dosing accuracy of the components:	$\leq \pm 0.25 \%$
Brix accuracy:	$\leq \pm 0.06^\circ$ Brix at a constant Brix value in sugar syrup or with a built-in accessory unit for the „Brix measurement in sugar syrup“
Dimensions:	To a certain extent the dimensions are dependent of the flow rate and the number of components. Example: Dimensions of a 4-components system with a blending flow rate of 20,000 l/h: Width 2,200 mm / height 2,000 mm / depth 1,200 mm.
Accessories:	<ul style="list-style-type: none">- Brix measurement in sugar syrup with an automatic correction of the ratio between water and sugar syrup- Control of the total flow rate by an automatic modulating valve in the line for sugar syrup- Measuring system in the concentrate lines for the recognition of any wrongly connected products- Analysis in finished syrup (e.g. density, Brix, conductivity)- Fixed connection for blowing out the concentrate lines (recommendable in case of frequent concentrate changes)- Automated CIP connection with leakage protection (see the scheme on page 1 of this data sheet)