

Data Sheet



Function

The sampler makes possible the continuous and aliquot sampling of liquids from pipelines. At every stroke the sampling quantity is taken from the pipeline between the rounded sealing surface and the piston point, and delivered down. Then the sample flows into the sampling bottle without pressure.

The ratio of sampling quantity to quantity of liquid flowing through the pipeline can be determined by modification of the stroke frequency.

At the end of the sampling process the product probably adhering to the surface can be discharged via an air purge connection. For this should be used by preference aseptic air. By that means a probable carry-over can be minimized.

During the cleaning process the piston rod should be moved, in order to rinse the sealing surfaces sufficiently. Furthermore, it is possible to take cleaning liquid from the pipeline via a valve combination to use it for cleaning the purge connection. A bottle fixing, adjustable to different bottle sizes, can be supplied optionally. For this the sampling bottle is pressed with the opening (\varnothing 45 mm max.) directly under the sampler, so that a contamination of the bottle from outside will be minimized.

Technical Data

Sample volume per stroke (can be calibrated in factory between)	0.35 or 1.8 cm ³ (design-dependent)
Product temperature	80°C max. (during cleaning process up to 100°C for a short time)
Pressure in the product pipeline	6 bar absolute
Stroke frequency	60 min ⁻¹
Air pressure	3 - 6 bar
Pneumatic fittings	for hose 4 x 1
Option	sampling bottle fixing purging valve cleaning valve
Fittings	DN 40 - 100/ welding socket acc. to DIN 11850
Material	1.4301
Sealings	EPDM/NBR
Sampling bottle size	50 ml and 500 ml (other sizes on request)
Purge medium	air (clean and oil-free)
Purge pressure	0.2 - 0.5 bar (install probably fine pressure reducer)
necessary for drive	1 x 4/2-way solenoid valve

GEA Diessel GmbH
Steven 1
D-31135 Hildesheim
Germany
☎ +49 (0)5121-742-0

Piston Sampler
Type PT

D 75.21E
Issued: 03.2005
Page 1 of 2

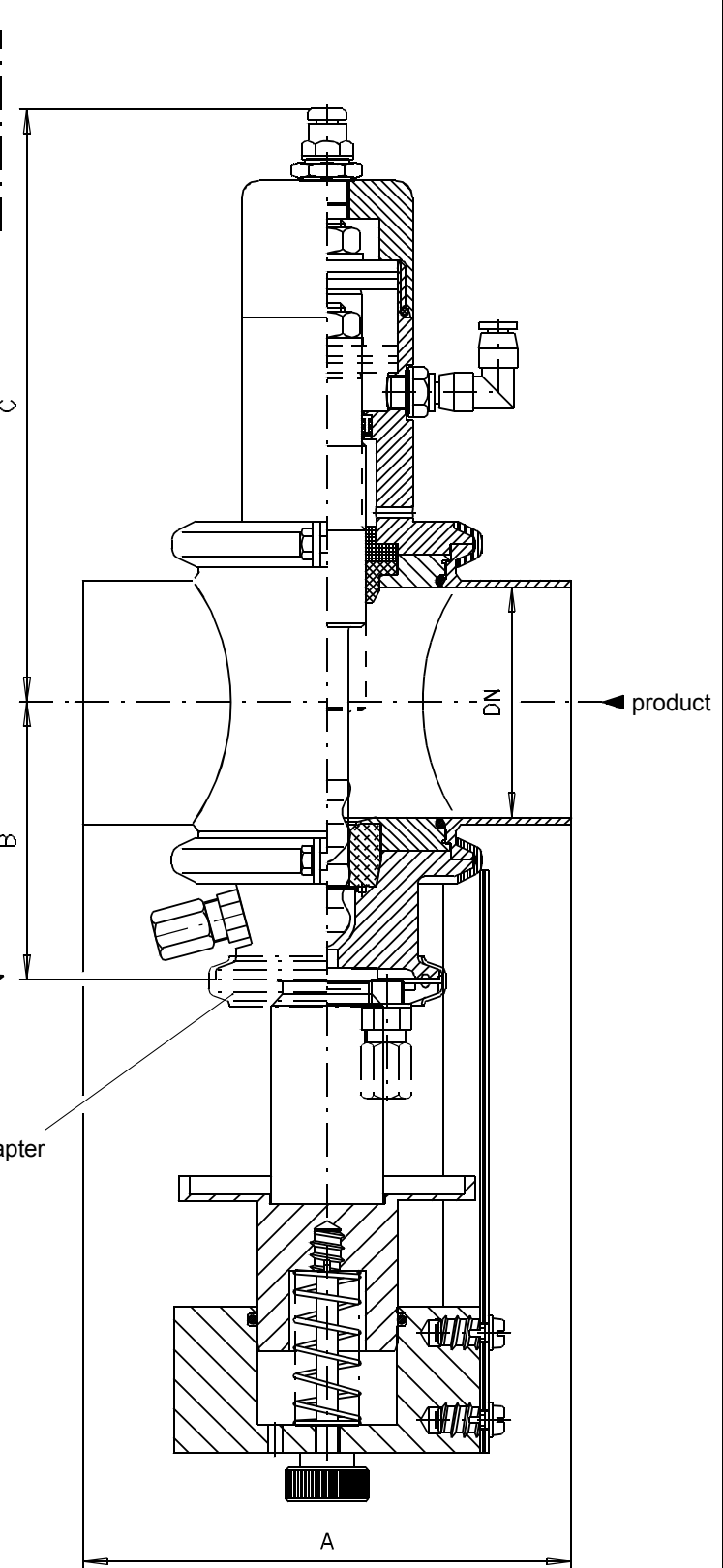
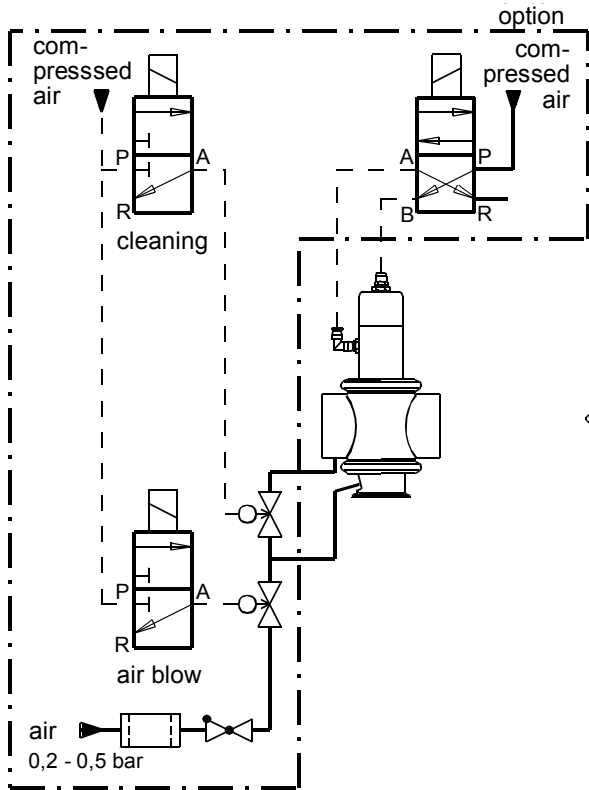

DN	A	B	C
40	180	65	155
50	180	72	162
65	250	80	170
80	250	88	178
100	250	97	187