

Data Sheet

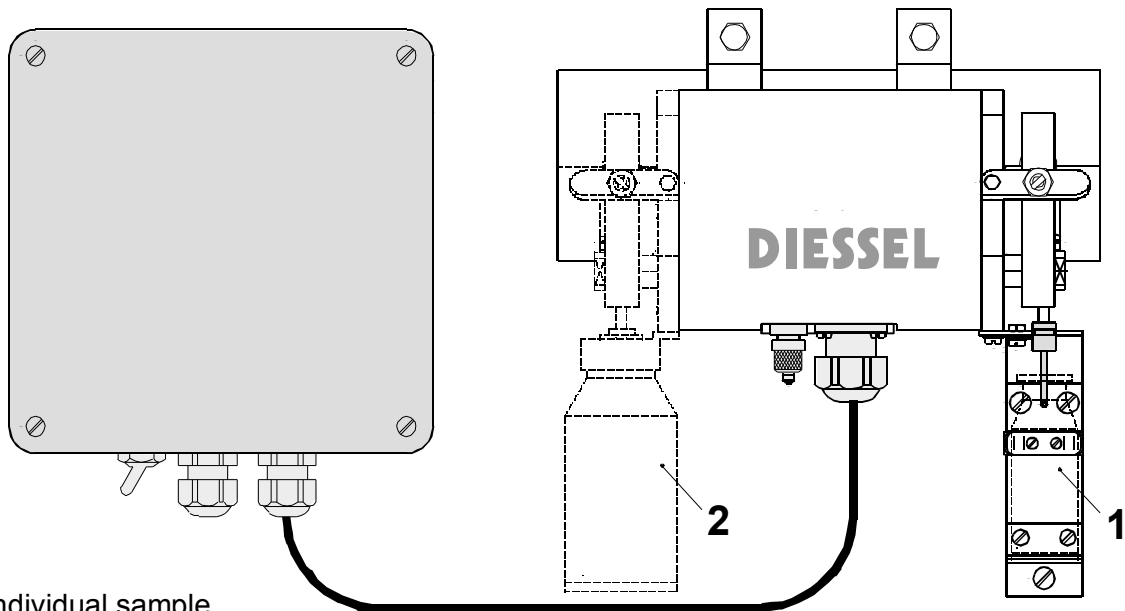

- 1 Individual sample
2 Tour sample

Description

The **Sampler PS4-S** designed to be installed on milk collecting trucks works according to the principle of a hose pump and enables you to take the samples directly from the hose pipe. The **PS4-S** can be equipped with two pump heads; it consists of the sampler in a stainless steel housing and a separate control unit in an aluminium housing.

Special Features:

- Simultaneous taking of 2 independent and individual samples possible.
- Quasi-continuous operation because step motors are used.
- Improved lifetime of the hose due to a redesigned pump head and speed limiter.
- Good representability due to a very low sampling volume of the individual samples and frequent taking of individual samples.
- Low carry-over because of small moistening areas in the system. Suitable for bacteriological sampling.
- Easy installation.
- Good cleaning capability.
- Few maintenance required.
- Bottle holders for different sizes; can be optionally fitted with a bottle sensor.

It is no problem to retrofit the device into an existing pipeline. The pipeline must be ripped up at an adequate point and fitted with two counter flanges. Then the **Sampler PS4-S** which is fitted with a tube piece and the required bottles is just mounted.

The triggering is carried out automatically by using the GEA Diessel data capture device ZEVODAT-M.

GEA Diessel GmbH
Steven 1
31135 Hildesheim
Germany
☎ +49 (0)5121-742-0

**Peristaltic Sampler
PS4-S**
with separate electronics
for external control by Zevodat

D 75.25 E

Issued: 01.2001

Page -1- of -2- pages

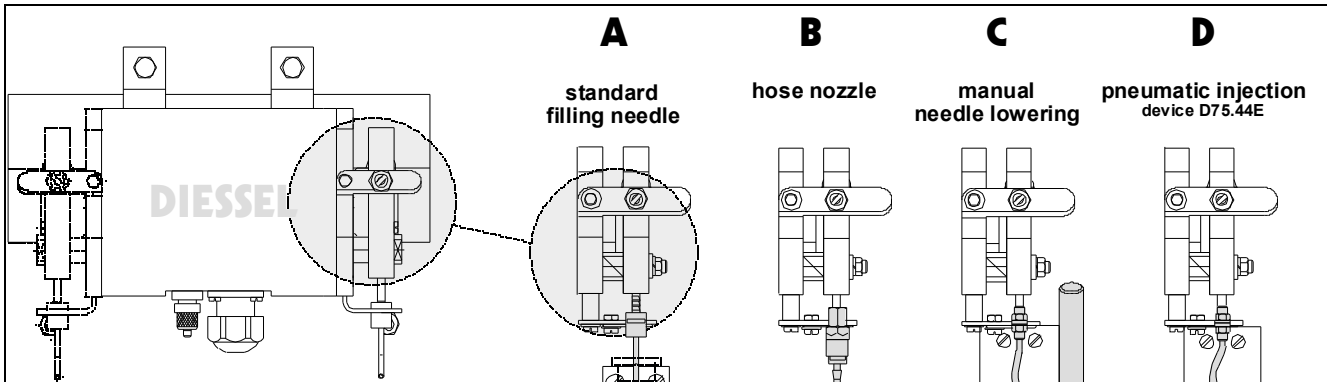

Version "A" with Filling Needle

The sample volume is directly filled to a sample bottle which is not closed.

Design "B" with Hose Nozzle

It is possible to carry out a low-germ filling of the taken sample by using a hose which is fixed to the hose nozzle at the sampler and by applying the adequate options.

Options: Version "C" or "D"

- Injection needle for a low-germ sampling process
- Sample bottle with slotted stopper made of caoutchouc.
- Magazine for several sample bottles for a fully automatic sampling process.

*) with connection for rinsing

Technical Data

Pipe connection	Connection of different nominal widths possible. Flange connection PN10 (small flange)			
Sampling volume	140 ml/min max. Attention: In case of small reception quantities it is indispensable to check the operating conditions in order to determine the attainable sampling volume. Standard value: 30 ml at an operating period of 20 seconds min.			
Pressure in the product pipe (pressure: bar absolute)	1 - 2.5 bar: Special design to be used at pressures below the atmospheric pressure (0.5 - 1 bar absolute) (Special adapter!)			
Materials	Stainless steel no. 1.4301 / Housing: Al lacquered Silicone hose			
Operating voltage	10 ... 30 V DC			
Current consumption for 2 motors (max.) when using one motor when using two motors		12 V DC	24 V DC	30 V DC
	Quiescent current	0.3 A	0.15 A	0.12 A
	Operating current	2.7 A	1.3 A	1.0 A
Fuse protection of the device	7.5 A (brown)			

Connection Scheme

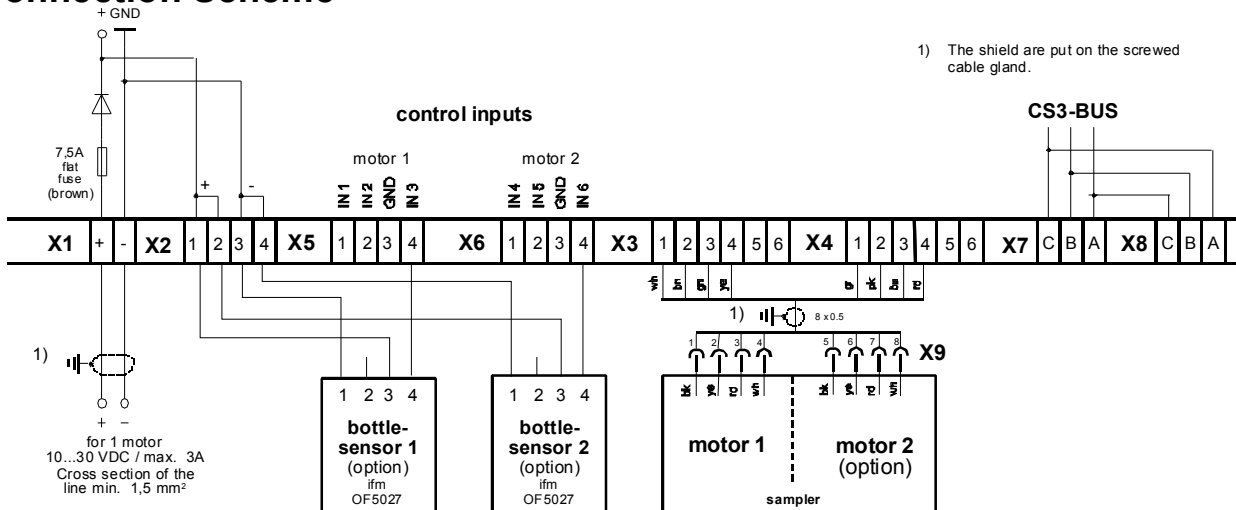

1) The shield are put on the screwed cable gland.

1) for 1 motor
10...30 VDC / max. 3A
Cross section of the line min. 1,5 mm²