

PS4S™ (D75.25E)

System with separate electronics for external control by Zevodat and with one or two pump heads

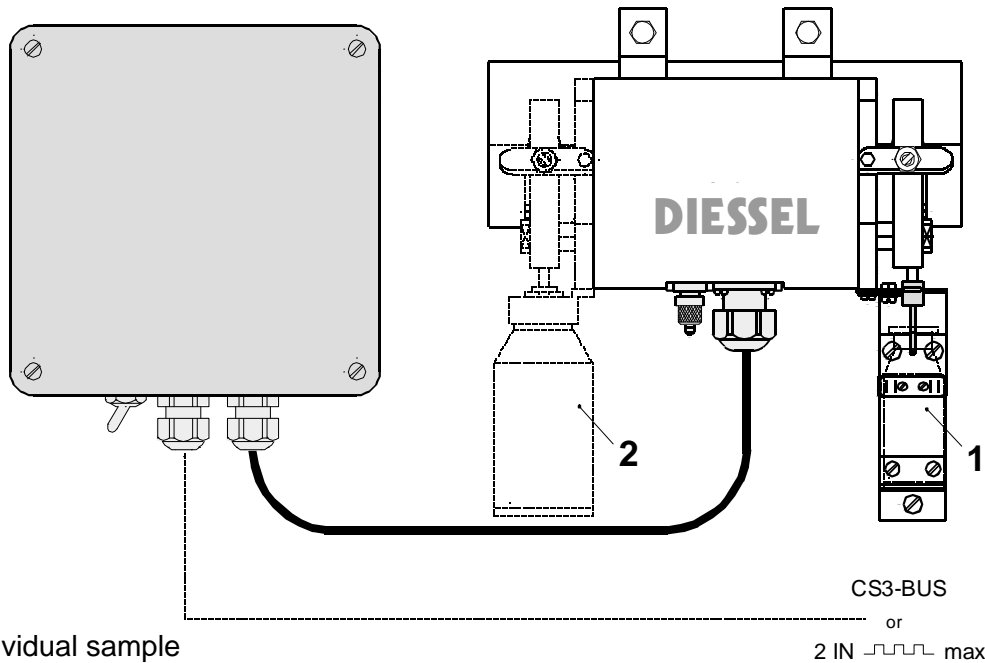

- 1 individual sample
- 2 four sample

PS4I™ (D75.26E)

“Stand alone” system with separate time or volume control, operating unit, and two pump heads

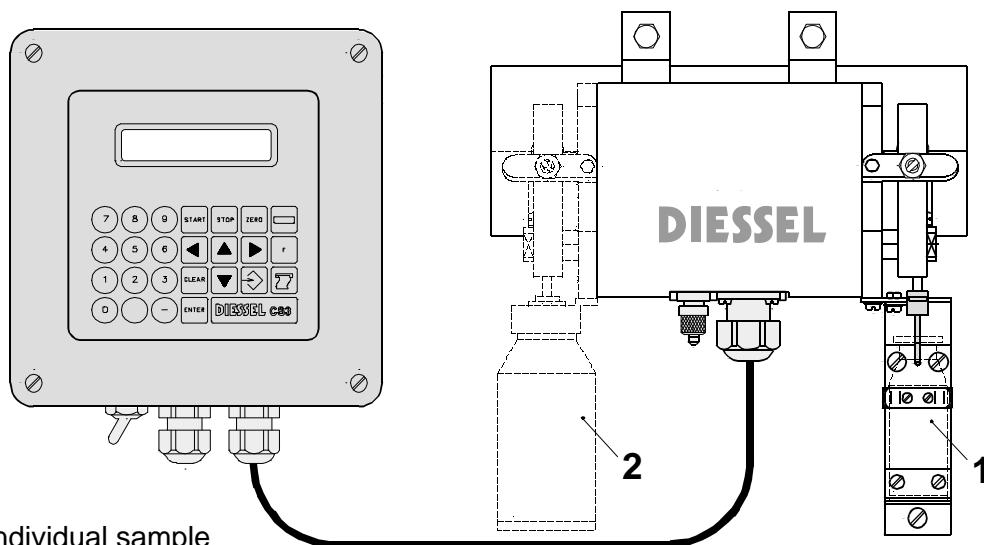

- 1 individual sample
- 2 four sample

Subject to technical alterations!

GEA Diesel GmbH
Steven 1
31135 Hildesheim
Germany
Phone: +49 (0)5121-742-0

Peristaltic Sampler
PS4™ Overview

D 75.27 E

Issued: 01.2005

Page -1- of -1- pages