

Parenterals

Complete solutions for
process plant



Parenterals: the right solution for every application



The production of parenterals, i.e. of injection and infusion solutions for medical application, is a matter requiring a particular degree of care and attention, since every possible risk to the patient must be excluded. As in the production of other liquid pharmaceutical preparations, the materials and processing have to meet the most stringent quality requirements. Absolute sterility is only one of the key factors in the manufacturing process. In addition, a large number of national and international standards and statutory provisions have to be complied with.

Characteristics of apparatus for the production of parenterals

- design free of dead-leg areas
- completely suitable for in-line CIP and SIP (cleaning/sterilisation in place)
- withstands temperatures of up to 150 °C
- aseptic sampling possible
- sterile filters for gases and fluids (testable in-line)
- minimisation of product losses by the use of block valves and valve rings
- use of aseptically connected transport vessels or of an isolator

Manufacturers of pharmaceuticals demand the very highest standards with regard to their production plant. Every detail of the design has to meet high quality requirements, in order to eliminate the risk of production errors. The use of high-performance processing equipment will in itself ensure that many of these conditions that are essential to smooth running production are fulfilled.

GEA Diessel faces up to these challenges. As a competent manufacturer of complete plant for the pharmaceutical industry, GEA Diessel offers you full service for every requirement and to meet every specification. From the planning, development, installation and qualification of your new process plant all the way to after-sales service and maintenance – our experienced engineers will collaborate with your project team to develop innovative and efficient process technologies for your own very individual parenteral applications.

GEA Diessel offers you:

- consultancy
- engineering
- automation
- manufacture of process vessels
- skids/units
- installation
- qualification
- assistance with validation
- after-sales service



Sterile sampling



Valve ring

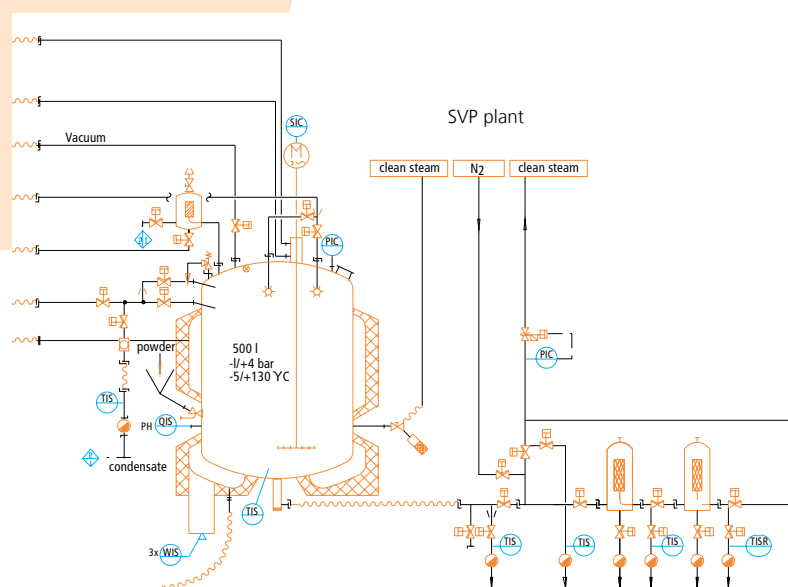



Clean room partition wall with integrated preparation vessel

High-tech components for optimum results

Whether it is infusion solutions, electrolytes, anaesthetics or vaccines that you produce, or whether you are a manufacturer of serums, injections, insulin or drop solutions, our great diversity of plant modules will perform any task and take account of any requirements or conditions. By using the latest components and valve technology and the latest, state-of-the-art manufacturing concepts for vessels and skids, we ensure that you will be able to use your plant to manufacture your products economically and under completely sterile conditions. Talk to us. Together, we will find the most appropriate solution to cover your requirements. We will be pleased to advise you.

Your manufacturing process	Our solutions
water supply/dosing:	<ul style="list-style-type: none"> • flow meter at inflow • mass metering in the vessel
adding of ingredients:	<ul style="list-style-type: none"> • Addition of raw materials by hand under aseptic conditions • intake of raw materials by suction under the surface level • aseptic attachment of sampling vessels
blending:	<ul style="list-style-type: none"> • frequency-regulated stirrers <ol style="list-style-type: none"> a) with double-acting rotating ring seal and sterilisable sealing liquid system b) magnetically coupled stirrers in the bottom of the container c) homogenisers
tempering:	<ul style="list-style-type: none"> • open or closed heating/cooling system with cascade regulation through the double jacket
sampling:	<ul style="list-style-type: none"> • sterilisable sampling system
transfer:	<ul style="list-style-type: none"> • centrifugal pump, rotary piston pump, draining of residues, suitable for CIP and SIP • sterilely filtered pressurised gas for blanketing
product filtration:	<ul style="list-style-type: none"> • preliminary filter and sterile filter, suitable for CIP / SIP • integrity testing in-line
storage:	<ul style="list-style-type: none"> • use of stirrers for homogenisation • nitrogen blanketing • aseptic sampling



Detail of container lid

Automation

We can offer you a selection of different well-proven system solutions for the control and recording of process data. We will supply the plant with whatever type of operating system you require: starting from manual operation by buttons and switches, and passing through control systems with operator control units or process visualisation, we can go all the way to I&C and/or batch systems capable of controlling several workstations. Process and formula-relevant data can be recorded in a log.

CIP / SIP

An essential part of a high-quality production of parenterals is an integrated CIP/SIP system. GEA Diessel provides efficient cleaning and sterilisation concepts adapted to the actual demands of the consumers and for a timely supply of the correct cleaning media to the points-of-use. From mobile and independent cleaning systems up to diverse CIP satellites fed with conditioned cleaning solutions the range of customised solutions for your process plant is large.



Parenteral plant



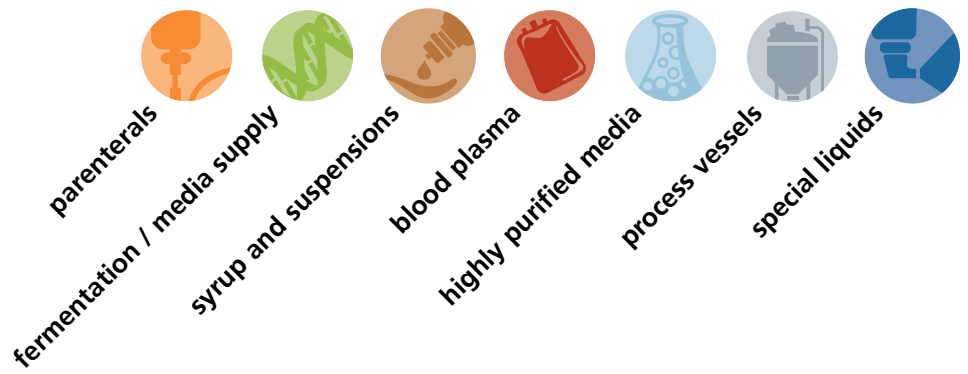

Parenterals

Complete solutions for process plant

GEA Diessel specializes in planning, construction and qualification of sterile process plant for liquids in pharmaceutical and biotechnology industry. Our process systems are operational within the area of parenterals, fermentation, feed media, blood plasma and special liquids as well as clean utilities.

GEA Diessel has 80 years of expertise and know-how in plant and equipment technology and holds a decisive position in development of modern process technology today.

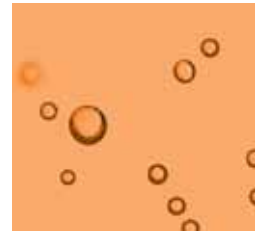

GEA Process Engineering

GEA Diessel GmbH

Steven 1 31135 Hildesheim Germany
Phone +49 5121 742-0 Fax +49 5121 742-153
info.geadiessel.de@geagroup.com www.diessel.com